

Submittal Data

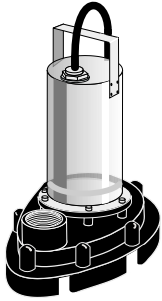

JOB or CUSTOMER:
ENGINEER:
CONTRACTOR:
SUBMITTED BY: DATE:
APPROVED BY: DATE:
ORDER NO: DATE:
SPECIFICATION REF:

QUANTITY	TAG NO.	MODEL NO.	GPM	FEET	VOLT	PHASE	COMMENTS
					115	1	
					115	1	
					115	1	

Repair Kit P/N

Technical Data

PERFORMANCE RANGE:

- 0 – 59 U.S. GPM
- 0 – 31 feet of water, TDH

SOLIDS HANDLING:

- 1/2" spherical solids (EF302)
- 3/4" spherical solids (EF332, EF402)

MOTOR TYPE:

- AC Induction • Oil filled
- Shaded pole • Class B insulation

MOTOR DUTY:

- Continuous, not to exceed 8 hours per 24 hour period

THERMAL PROTECTION:

- Automatic reset

STARTS PER HOUR:

- 20 starts per hour maximum evenly distributed once every 3 minutes

MOTOR BEARING SYSTEM:

- 2 bronze sleeve bushings

TEMPERATURE LIMITS:

Fluid temperature, pump fully submerged

- Normal motor duty - 104°F (40° C)
- Intermittent operation (approx. 3-4 minutes - 132°F (55° C))

DISCHARGE SIZE:

- 1 1/2" female NPT

IMPELLER DESIGN:

- Semi-open centrifugal

APPROVALS: Listed 99K4 c

Performance Curves 3000 RPM 60 Hertz

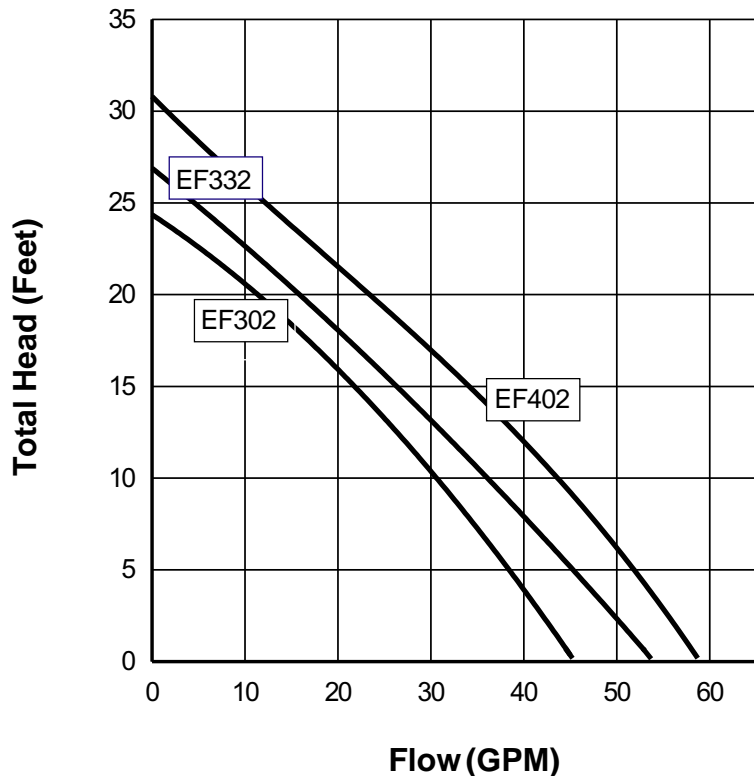

Electrical Data, Weights and Volume

Pump Type	HP	Service Factor	PH	Input Voltage	Max. Power Consumption (Watts)	Max. Current (Amps)	Locked Rotor Current (Amps)	Shipping Volume (Cu Ft.)	Ship Wt. Pump w/Power Cord		Ship Wt. Pump w/ Power Cord & Switch	
									10'	20'	10'	20'
EF302	3/10	1.15	1	115	675	8.5	12	.50	12.3	12.8	12.8	13.3
EF332	1/3	1.15	1	115	800	10.8	14	.50	13.0	13.5	13.4	14.0
EF402	2/5	1.15	1	115	1000	14.5	20	.50	14.3	14.8	14.8	15.3

Dimensions

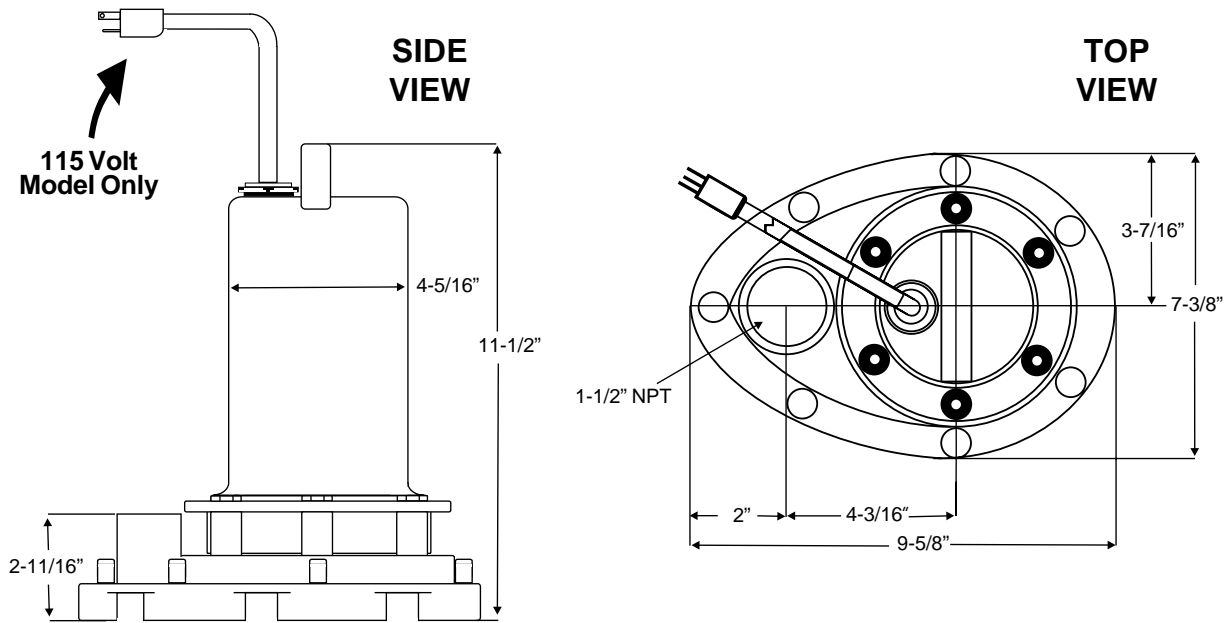

Materials of Construction

Description	Material
Volute	Glass filled engineered composite
Shaft Seal	EF302 - Double NBR lip seal EF332, EF402 - Single carbon-ceramic mechanical seal
Impeller	Glass filled engineered composite
Motor Housing	316 Stainless Steel
Power Cord	SJOW-A-Neoprene

Type Designation

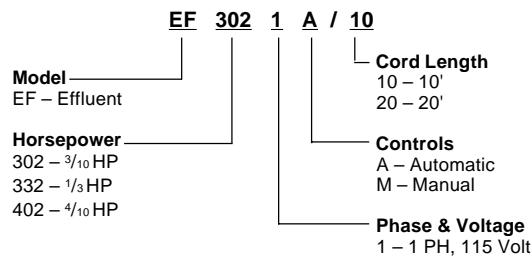

GRUNDFOS®



Leaders in Pump Technology

Grundfos Pumps Corporation • 3131 N. Business Park Avenue • Fresno, CA 93727

Customer Service Centers: Allentown, PA • Fresno, CA

Phone: (800) 333-1366 • Fax: (800) 333-1363

Canada: Oakville, Ontario • Mexico: Apodaca, N.L.

Visit our website at www.us.grundfos.com



L-SE-TL-017 07/00
PRINTED IN USA